

**BALDOR® • RELIANCE** 

**Product Information Packet**

**IDM3587T**

**2HP, 1755RPM, 3PH, 60HZ, 145TC, 0533M, TEBC, F1**

Part Detail							
Revision:	U	Status:	PRD/A	Change #:		Proprietary:	No
Type:	AC	Elec. Spec:	05WGW710	CD Diagram:	CD0005	Mfg Plant:	
Mech. Spec:	05E535	Layout:	05LYE535	Poles:	04	Created Date:	12-06-2006
Base:	RG	Eff. Date:	06-26-2019	Leads:	9#18		

Specs			
Catalog Number:	IDM3587T	Insulation Class:	H
Enclosure:	TEBC	Inverter Code:	Inverter Duty
Frame:	145TC	KVA Code:	L
Frame Material:	Iron	Lifting Lugs:	Standard Lifting Lugs
Output @ Frequency:	2.000 HP @ 60 HZ	Locked Bearing Indicator:	Locked Bearing
Synchronous Speed @ Frequency:	1800 RPM @ 60 HZ	Motor Lead Quantity/Wire Size:	9 @ 18 AWG
Voltage @ Frequency:	460.0 V @ 60 HZ	Motor Lead Exit:	Ko Box
	230.0 V @ 60 HZ	Motor Lead Termination:	Flying Leads
XP Class and Group:	None	Motor Type:	0534M
XP Division:	Not Applicable	Mounting Arrangement:	F1
Agency Approvals:	CSA	Power Factor:	79
	UR	Product Family:	General Purpose
Auxillary Box:	No Auxillary Box	Pulley End Bearing Type:	Ball
Auxillary Box Lead Termination:	None	Pulley Face Code:	C-Face
Base Indicator:	Rigid	Pulley Shaft Indicator:	Standard
Bearing Grease Type:	Polyrex EM (-20F +300F)	Rodent Screen:	None
Blower:	BLOWER	RoHS Status:	ROHS COMPLIANT
Current @ Voltage:	2.700 A @ 460.0 V	Shaft Extension Location:	Pulley End

	5.400 A @ 230.0 V	<b>Shaft Ground Indicator:</b>	No Shaft Grounding
	5.600 A @ 208.0 V	<b>Shaft Rotation:</b>	Reversible
<b>Design Code:</b>	B	<b>Shaft Slinger Indicator:</b>	Shaft Slinger
<b>Drip Cover:</b>	No Drip Cover	<b>Speed Code:</b>	Single Speed
<b>Duty Rating:</b>	CONT	<b>Motor Standards:</b>	NEMA
<b>Electrically Isolated Bearing:</b>	Not Electrically Isolated	<b>Starting Method:</b>	Direct on line
<b>Feedback Device:</b>	NO FEEDBACK	<b>Thermal Device - Bearing:</b>	None
<b>Front Face Code:</b>	Encoder/Feedback Device	<b>Thermal Device - Winding:</b>	Normally Closed Thermostat
<b>Front Shaft Indicator:</b>	None	<b>Vibration Sensor Indicator:</b>	No Vibration Sensor
<b>Heater Indicator:</b>	No Heater	<b>Winding Thermal 1:</b>	None
		<b>Winding Thermal 2:</b>	None

Nameplate NP1162L	
CAT NO	IDM3587T
SPEC.	05E535W710G1
FRAME	145TC HP 2 TE
VOLTS	230/460
MAG CUR	2.9/1.45 FLA 5.4/2.7
RPM	1755 RPM MAX 6000
HZ	60 PH 3 CLASS H
SER.F.	1.00 DES B SL HZ 1.5
NEMA-NOM-EFF	88.5 WK2 0.201
BLWR V	115 PH 1 HZ 60 A .5
RATING	40C AMB-CONT
DE BRG	6205 ODE BRG 6203
CC	010A SN

Parts List		
Part Number	Description	Quantity
SA151282	SA 05E535W710G1	1.000 EA
RA140105	RA 05E535W710G1	1.000 EA
LB1115N	LABEL,LIFTING DEVICE (ON ROLLS)	1.000 EA
HW3201A05	3/8-16 EYEBOLT	1.000 EA
WD1000B16	T&B CX70TN OR L70P TERMINAL LUG	1.000 EA
10XN2520A06	1/4 20X3/8 HX HD CAP	2.000 EA
06CB3000	BALDOR CONDUIT BOX CAST	1.000 EA
06GS1000	GASKET,CONDUIT BOX	1.000 EA
51XW2520A12	SCREW, HEX SER SLT HD, ZN, 1/4-20 X .75	2.000 EA
11XW1032G06	10-32 X .38, TAPTITE II, HEX WSHR SLTD U	1.000 EA
HW3001B01	BRASS CUP WASHER, FOR #10 SCREW	1.000 EA
35EP1100B21	FRONT TEBC 203 BRG W/ GREASER & THRU-SHA	1.000 EA
HW4500A01	1641B(ALEMITE)400 UNIV, GREASE FITT	1.000 EA
HW5100A03	WAVY WASHER (W1543-017)	1.000 EA
35EP1329A01	PU EP ENCL 143-5TC 205 BRG W/GRSR & STD	1.000 EA
HW4500A01	1641B(ALEMITE)400 UNIV, GREASE FITT	1.000 EA
51XN1032A20	10-32 X 1 1/4 HX WS SL SR	2.000 EA
HA3100A28	THRUBOLT 10-32 X 8.187	4.000 EA
10XN2520A08	1/4-20X1/2 HEX HEAD CAP	1.000 EA
HA3218A04	MALE-FEMALE STANDOFF .25-.20 .38 HEX	3.000 EA
10XN2520A04	1/4-20 X 1/4 HEX HD MACH SCREW	3.000 EA
HW1003A25	WASHER, 1/4 EX TH LK, ZN X	3.000 EA
06CB3500	BALDOR CONDUIT BOX LID	1.000 EA
06GS1001	BALDOR CONDUIT BOX GASKET	1.000 EA

<b>Parts List (continued)</b>		
<b>Part Number</b>	<b>Description</b>	<b>Quantity</b>
51XW2520A12	.25-20 X .75, TAPTITE II, HEX WSHR SLTD	2.000 EA
HA1005A05SP	SLINGER, OD 1.50, ID .659, 203 BRG	1.000 EA
HW2501D13	KEY, 3/16 SQ X 1.375	1.000 EA
HA7000A01	KEY RETAINER 7/8" DIA SHAFT	1.000 EA
MJ5004A05	#242-21 LOCTITE GENERAL PURPOSE MED. STR	0.005 EA
85XU0407S04	4X1/4 U DRIVE PIN STAINLESS	2.000 EA
LB1009N	LABEL,ROTATION DIRECTION (ON ROLLS)	1.000 EA
MJ1000A02	GREASE, MOBIL POLYREX EM - 124047	0.050 LB
05FH5001A03	BLOWER KIT,05FH4002,EF0008,35CB3002	1.000 EA
MG1000G27	MED CHARCOAL METALLIC GREY 400-0096	0.022 GA
LC0035B01	1PH, SV, FIX, 2 LEAD	1.000 EA
LB1119N	WARNING LABEL	1.000 EA
LC0145B01	CONNECTION LABEL	1.000 EA
NP1162L	SS INV UL CSA CC	1.000 EA
G7PA1000	PKG GRP, PRINT PK1034A06	1.000 EA
MN416A01	TAG-INSTAL-MAINT no wire (1200/bx) 3/19	1.000 EA

AC Induction Motor Performance Data

Page 1 of 1



**AC Induction Motor Performance Data**

Record # 36397

Typical performance - not guaranteed values

<b>Winding:</b> 05WGW710	<b>Type:</b> 0533M	<b>Enclosure:</b> TEBC
--------------------------	--------------------	------------------------

Nameplate Data			General Characteristics at 460 V, 60 Hz: High Volt Connection		
Rated Output (HP)	2		Full Load Torque	5.95 LB-FT	
Volts	230/460		Start Configuration	DOL	
Full Load Amps	5.4/2.7		Break Down Torque	26.6 LB-FT	
R.P.M.	1755		Pull-Up Torque	15.2 LB-FT	
Hz	60	Phase	3	Locked-rotor Torque	18.2 LB-FT
NEMA Design Code	B	KVA Code	L	Starting Current	24.7 Amps
Service Factor	1		No-load Current	1.45 Amps	
NEMA Nom. Eff.	88.5	P.F.	79	Line-line Res. @ 25°C.	6.79 Ohms
Rating - Duty	40C AMB-CONT		Temp. Rise @ Rated Load	36°C	
S.F. Amps			Temp. Rise @ S.F. Load		

Load Characteristics at 460 Volts, 60 Hz, 2 HP

% of Rated Load	25	50	75	100	125	150	S.F.
Power Factor	38	59	71	79	84	86	
Efficiency	81	87.1	88.6	88.6	87.6	86.4	
Speed	1788	1779	1769	1758	1746	1733	
Line Amperes	1.57	1.84	2.25	2.67	3.21	3.82	

Baldor Electric Company Fort Smith, Arkansas



Catalog	IDM3587T	NIP VOLTS	230/460	ENCLOSURE	TEBC	WYE CONNECTION OHMS PER PHASE (BASE RATING, 200°)			
FRAME	145TC	NIP AMPS	5.4/2.7	Base Volts	460	R1	3.330	X1	6.558
HP	2 HP	DUTY	Cont	Base AMPS	2.67	R2	2.230	X2	5.753
BASE SPEED	1800	MAX SAFE RPM	6000	Slip Hz	1.40			XMI	170.353
PHASE/HZ	3/60	AMB° C/INSUL	40/H	WK <sup>2</sup> (lb-ft <sup>2</sup> )	0.195				

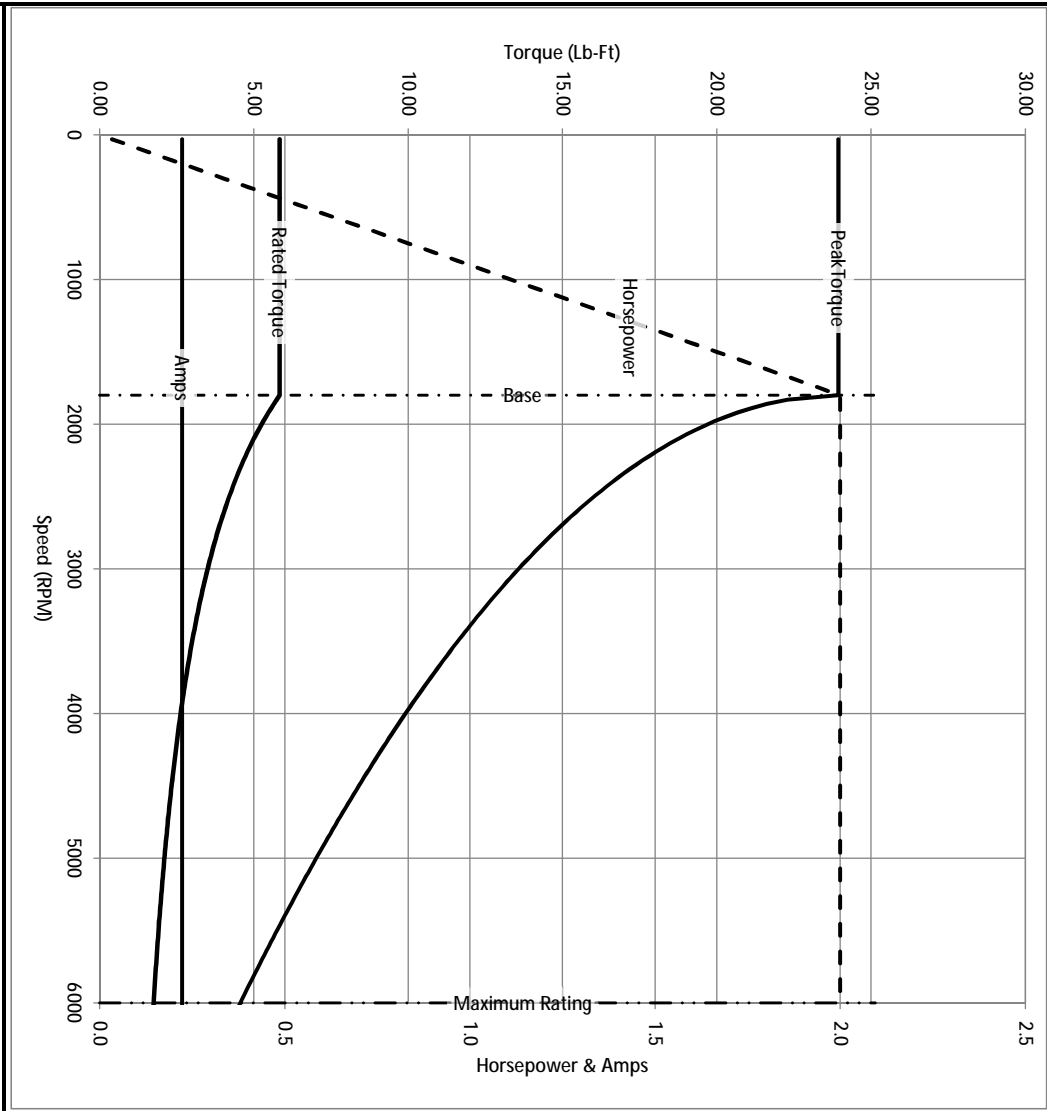

Remarks: Calculated Data

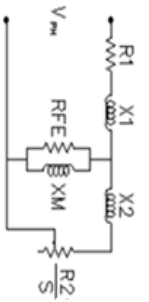

<p>A MEMBER OF THE ABB GROUP</p>	DR BY <u>ENR</u> CK BY APP BY DATE <u>2/26/2013</u>	A-C MOTOR PERFORMANCE CURVES	05E535W710G1 ISSUE DATE <u>2/26/2013</u>
----------------------------------	--	---------------------------------	---

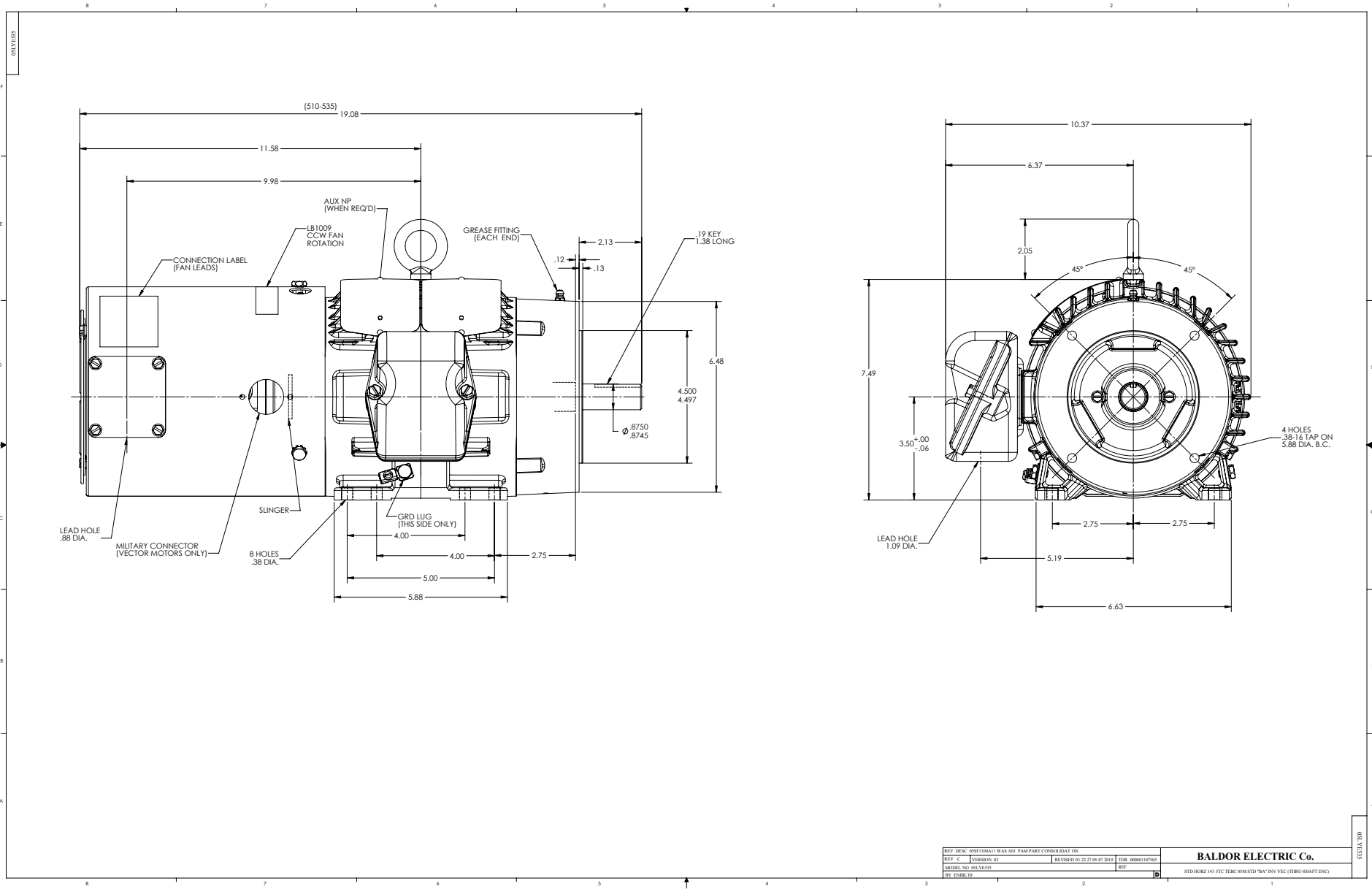

REV. DESC. 002/08/01 WAS AIR PUMP/RE CONSIDERATE ON	BALDOR ELECTRIC Co.		0533M.F01
REV. C INTERSON 02	REVISED 01/22/27/01/07/2019	IDR 00000107501	
MODEL NO. 0533E35	REF	STD 1002Z 145 TC TEBC 05M STD '0A' NV VIC (DRUG-SHAFT ENC)	
BY ENR110			

CD0005



LOW VOLTAGE  
(2Y)



LINE

HIGH VOLTAGE  
(1Y)

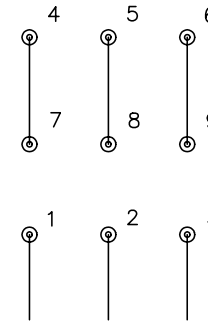

LINE

NOTES:

1. INTERCHANGE ANY TWO LINE LEADS TO REVERSE ROTATION.
2. OPTIONAL THERMOSTATS ARE PROVIDED WHEN SPECIFIED.
3. ACTUAL NUMBER OF INTERNAL PARALLEL CIRCUITS MAY BE A MULTIPLE OF THOSE SHOWN ABOVE.
4. LEAD COLORS ARE OPTIONAL. LEADS MUST ALWAYS BE NUMBERED AS SHOWN.

REV. DESC: REVISE TO SHOW OPTIONAL COLORS			
REV. LTR: E	BY: JLP	REVISED: 01/19/99 10:15	TDR: 0171435
90000		FILE: AAA00005140	MDL: -
		MTL: -	

**BALDOR ELECTRIC Co.**

3PH, DV, 9 LEADS

CD0005